

# TransSolve

2007



*Take the guesswork out of transport*



# Legal maximum Payloads

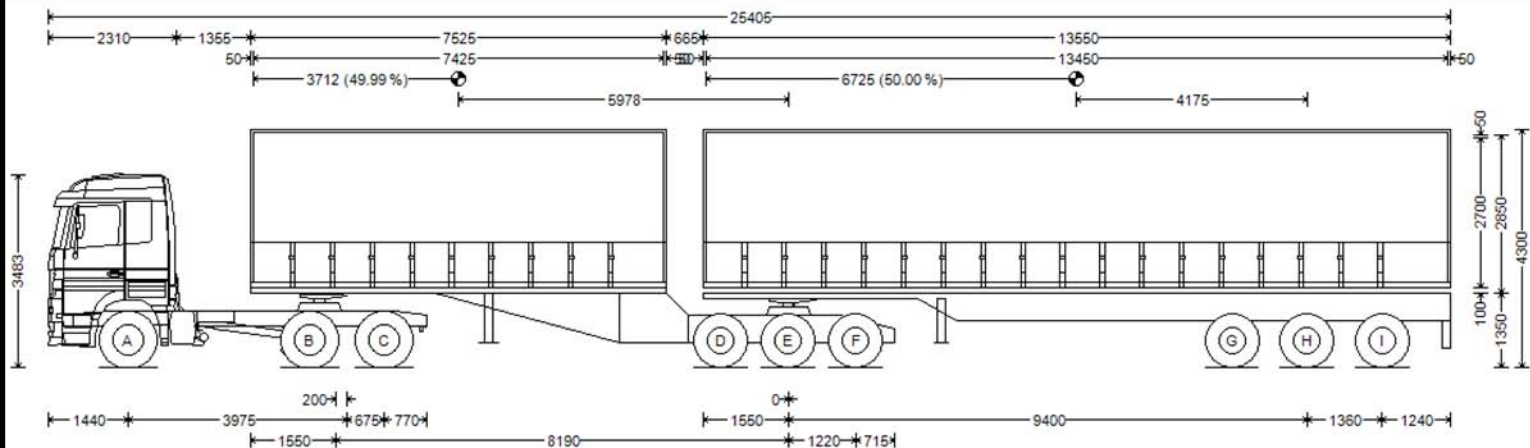

Veh. Front	Veh. Rear		Trailer 1	Total	Trailer 2
5,263 kg	3,438 kg	Unladen Veh.		8,701 kg	
105 kg	1,991 kg	Unladen Tr. 1	5,244 kg	7,340 kg	
0 kg	0 kg	Unladen Tr. 2	1,865 kg	8,100 kg	6,235 kg
5,368 kg	5,429 kg	Unladen Tot.	7,109 kg	24,141 kg	6,235 kg
551 kg	10,398 kg	Payload Tr. 1	4,051 kg	15,000 kg	
0 kg	0 kg	Payload Tr. 2	8,439 kg	19,000 kg	10,561 kg
551 kg	10,398 kg	Payload Tot.	12,490 kg	34,000 kg	10,561 kg
<b>5,919 kg</b>	<b>15,827 kg</b>	Gross	<b>19,599 kg</b>	<b>58,141 kg</b>	<b>16,796 kg</b>
6,000 kg	16,500 kg	Permissible	20,000 kg	62,500 kg	20,000 kg
<b>-1.35 %</b>	<b>-4.08 %</b>	Overload	<b>-2.01 %</b>	<b>-6.97 %</b>	<b>-16.02 %</b>



Simulation Speed

Trip Time	07H51
Distance	577.2 KM
Ø Speed	73.4 KM/H
Fuel	245.5 L
Ø Fuel	42.5 L
Current Gear	0



Rutland Rd. Parkwood, Johannesburg (GT) -> Esplanade, Durban (KZ)



# Routing and Performance



TransSolve 2007 - Mercedes-Benz Actros 2650LS-33 [Mercedes-Benz Actros 2650LS-33 + B Double Trailers.tsv]

File Reference Tools Help

New Open Save Properties Print Preview Email

Loading Routing Performance Finance Maintenance Costing Specification

### Finance Details

Description	Price	Discount	Net Price
Vehicle Mercedes-Benz Actros 2650LS-33	\$ 250,000.00	\$ 5,000.00	\$ 245,000.00
Extras	\$ 80,000.00		\$ 80,000.00
<b>Sub Total</b>			\$ 325,000.00
GST			\$ 32,500.00
Licence/Registration			\$ 0.00
Deposit			( \$ 0.00 )
Trade-in			( \$ 0.00 )
<b>Total</b>			\$ 357,500.00

Additional Notes

### Finance Options

**FML/Rental**

Period: 60 months  
Interest: 7.00 %  
Vehicle Residual: 0.00 %

**Finance (Arr)** \$ 6,435.39  
Maintenance \$ 0.00  
Insurance \$ 0.00  
GST R 643.54  
**Total** \$ 7,078.93  
Residual R 0.00

**Instalment Sale**

Period: 60 months  
Interest: 7.00 %

**Finance (Arr)** \$ 6,435.39  
Maintenance \$ 0.00  
Insurance \$ 0.00  
GST R 643.54  
**Total** \$ 7,078.93

**Lease**

Period: 60 months  
Interest: 7.00 %  
Vehicle Residual: 0.00 %

**Finance (Arr)** \$ 6,435.39  
Maintenance \$ 0.00  
Insurance \$ 0.00  
GST R 643.54  
**Total** \$ 7,078.93  
Residual R 0.00

**Outright Purchase**

Period: 60 months  
Cost of Capital: 4.00 %  
Vehicle Residual: 0.00 %

**Depreciation** \$ 5,416.67  
**Cost of Capital** \$ 568.70  
Insurance \$ 0.00  
GST R 0.00  
**Total** \$ 5,985.37  
Residual R 0.00

# Maintenance Rates

TransSolve 2007 - Mercedes-Benz Actros 2650LS-33 [Mercedes-Benz Actros 2650LS-33 + B Double Trailers.tsv]

File Reference Tools Help

New Open Save Properties Print Preview Email

Loading Routing Performance Finance Maintenance Costing Specification

## Contract Details

Contract Type Service Contract (unlimited service kilometres/hours)

Rate Escalating

## Contract Options

1st Service Interval 25,000 km (max. contract distance = 1,050,000 km) (max. contract months = 60)

### Option 1

Distance Per Month	12,500 km
Contract Months	60 months
Total Contract Distance	750,000 km
Monthly Rate	\$ 1,960.08
Cost/km	15.68 c/km
Excess Kilometre Levy	19.60 c/km

### Option 2

Distance Per Month	10,000 km
Contract Months	60 months
Total Contract Distance	600,000 km
Monthly Rate	\$ 1,588.07
Cost/km	15.88 c/km
Excess Kilometre Levy	19.85 c/km

### Option 3

Distance Per Month	8,000 km
Contract Months	60 months
Total Contract Distance	480,000 km
Monthly Rate	\$ 1,254.65
Cost/km	15.68 c/km
Excess Kilometre Levy	19.60 c/km

2nd Service Interval 15,000 km (max. contract distance = 750,000 km) (max. contract months = 60)

### Option 1

Distance Per Month	12,500 km
Contract Months	60 months
Total Contract Distance	750,000 km
Monthly Rate	\$ 3,153.33
Cost/km	25.23 c/km
Excess Kilometre Levy	31.54 c/km

### Option 2

Distance Per Month	10,000 km
Contract Months	60 months
Total Contract Distance	600,000 km
Monthly Rate	\$ 2,516.58
Cost/km	25.17 c/km
Excess Kilometre Levy	31.46 c/km

### Option 3

Distance Per Month	8,000 km
Contract Months	60 months
Total Contract Distance	480,000 km
Monthly Rate	\$ 2,037.28
Cost/km	25.47 c/km
Excess Kilometre Levy	31.84 c/km

# Operating Costs

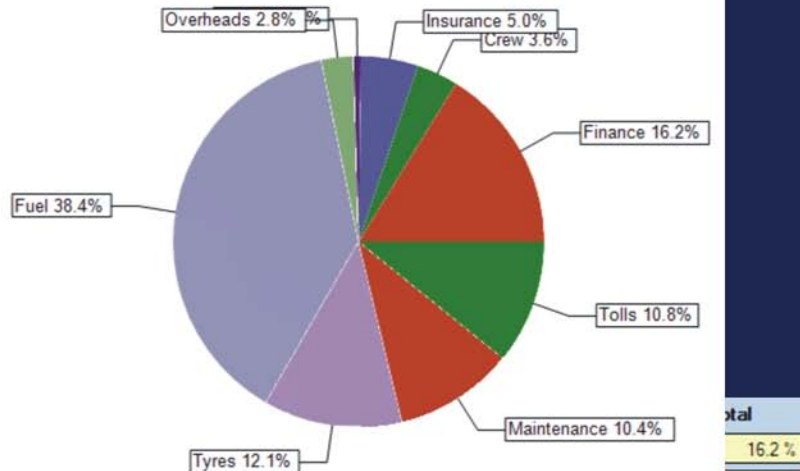

Fixed Costs	R/annum	R/km	R/unit	% Variable	% Total
Finance	R 404,962.92	R			16.2%
Crew	R 90,480.00	R			3.6%
Insurance	R 126,000.00	R 0.37	R 10.58	17.8%	5.0%
Licence Fees	R 15,282.00	R 0.04	R 1.28	2.2%	0.6%
Other Vehicle Expenses	R 0.00	R 0.00	R 0.00	0.0%	0.0%
Overheads	R 70,747.21	R 0.21	R 5.94	10.0%	2.8%
<b>Sub Total</b>	<b>R 707,472.13</b>	<b>R 2.06</b>	<b>R 59.42</b>	<b>100.0%</b>	<b>28.3%</b>
Variable Costs	R/annum	R/km	R/unit	% Variable	% Total
Fuel and Lubricants	R 959,686.99	R 2.79	R 80.60	53.6%	38.4%
Tyres	R 301,883.35	R 0.88	R 25.35	16.9%	12.1%
Maintenance	R 259,375.70	R 0.75	R 21.78	14.5%	10.4%
Toll Fees and Permits	R 269,535.00	R 0.78	R 22.64	15.1%	10.8%
Other Vehicle Expenses	R 0.00	R 0.00	R 0.00	0.0%	0.0%
<b>Sub Total</b>	<b>R 1,790,481.04</b>	<b>R 5.21</b>	<b>R 150.37</b>	<b>100.0%</b>	<b>71.7%</b>
<b>Total Costs</b>	<b>R 2,497,953.17</b>	<b>R 7.27</b>	<b>R 209.79</b>		<b>100.0%</b>
Profit	R 499,590.63	R 1.45	R 41.96		20.0%
<b>Total Revenue</b>	<b>R 2,997,543.80</b>	<b>R 8.72</b>	<b>R 251.75</b>		<b>120.0%</b>